

CONFIDENTIAL
 This document contains trade secrets or otherwise confidential information owned by MTH Manufacturing Inc..
 Access to and use of this information is strictly limited and controlled by MTH Manufacturing Inc..
 This document may not be copied, distributed, or otherwise disclosed outside of the Company's facilities
 except under appropriate precautions to maintain the confidentiality hereof, and may not be used
 in any way not expressly authorized by the Company.

REV		ZONE	DESCRIPTION	DATE	APPROVED
A			RELEASED FOR PRODUCTION	7-09-2021	MAH

FRONT VIEW

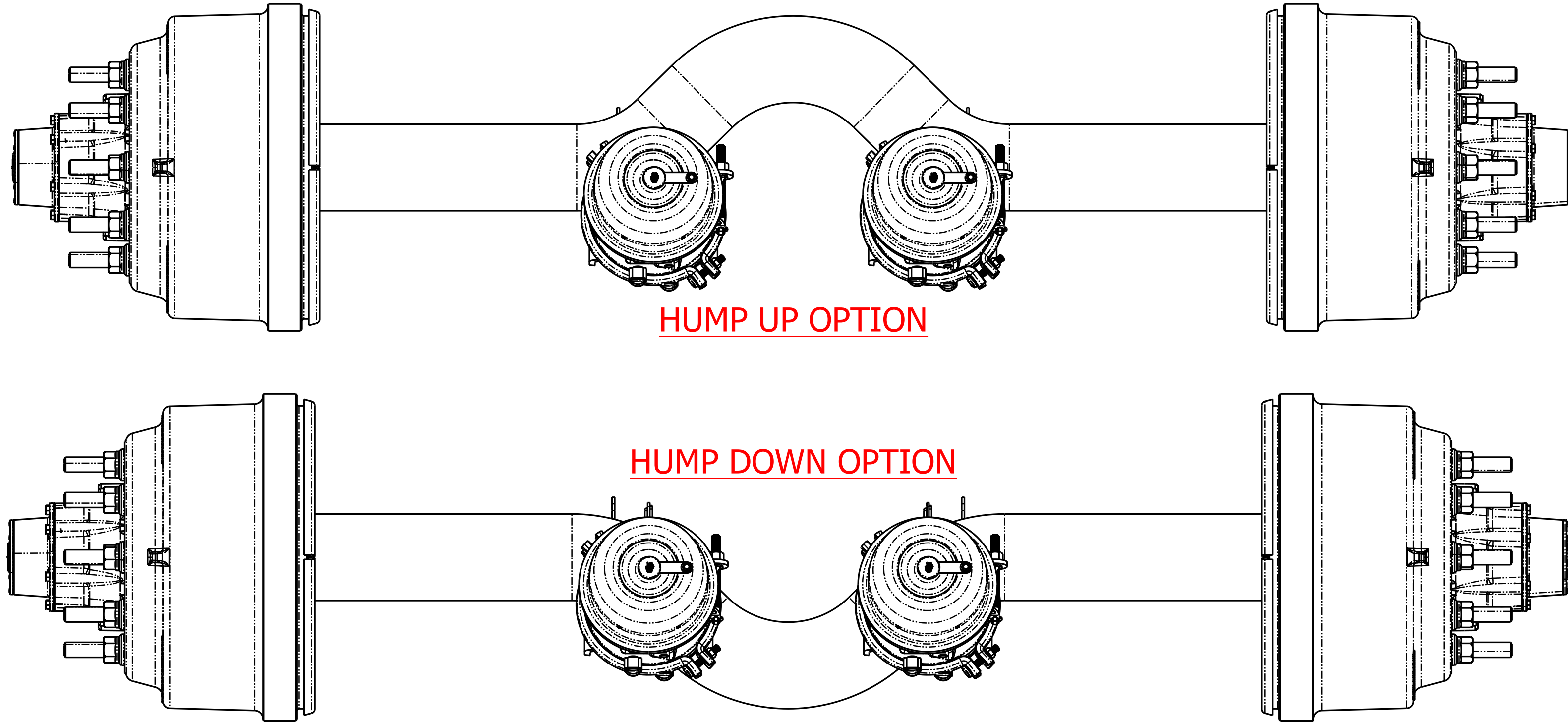

HUMP UP OPTION

HUMP DOWN OPTION

REAR VIEW

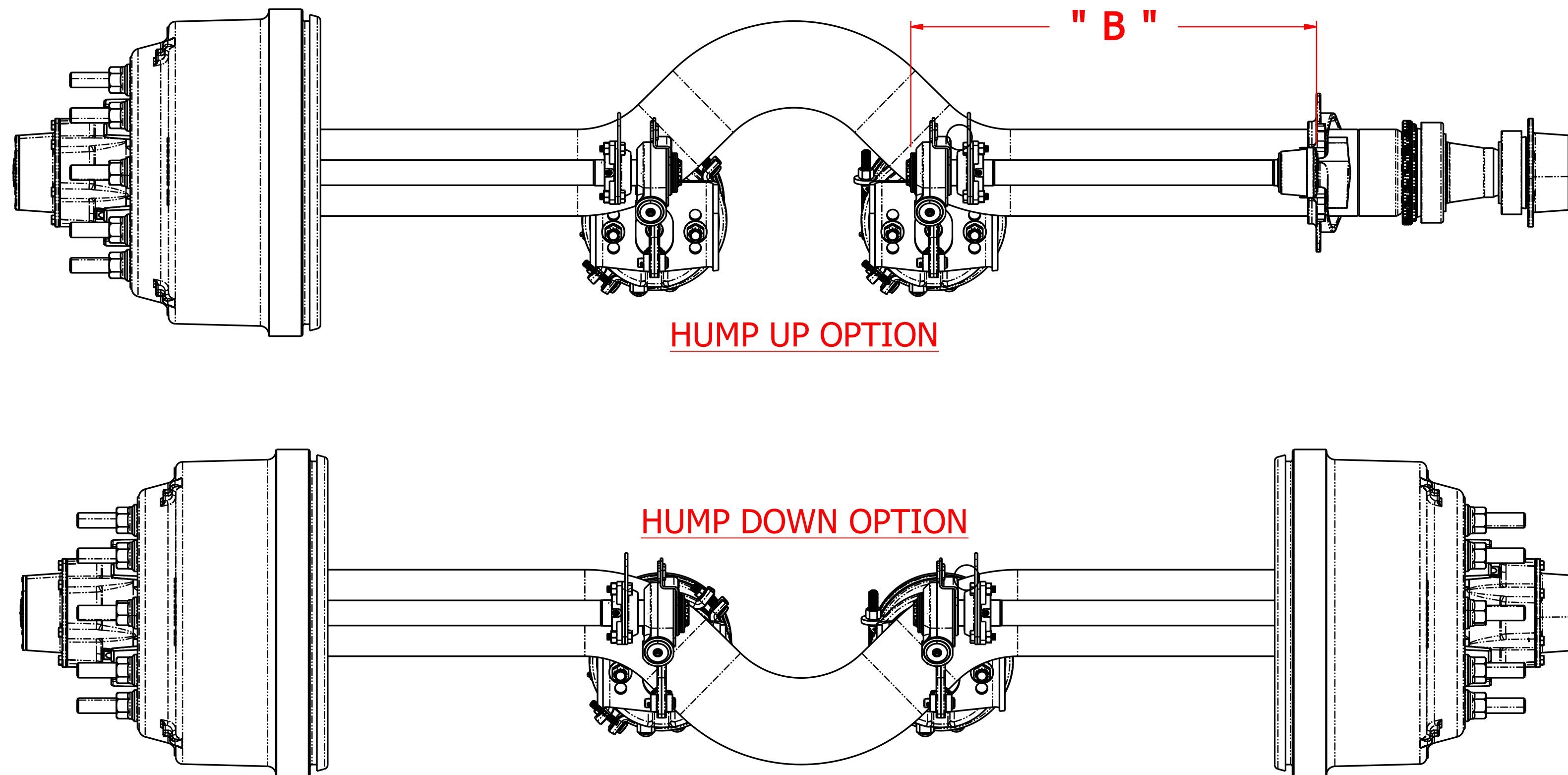

HUMP UP OPTION

HUMP DOWN OPTION

FORWARD

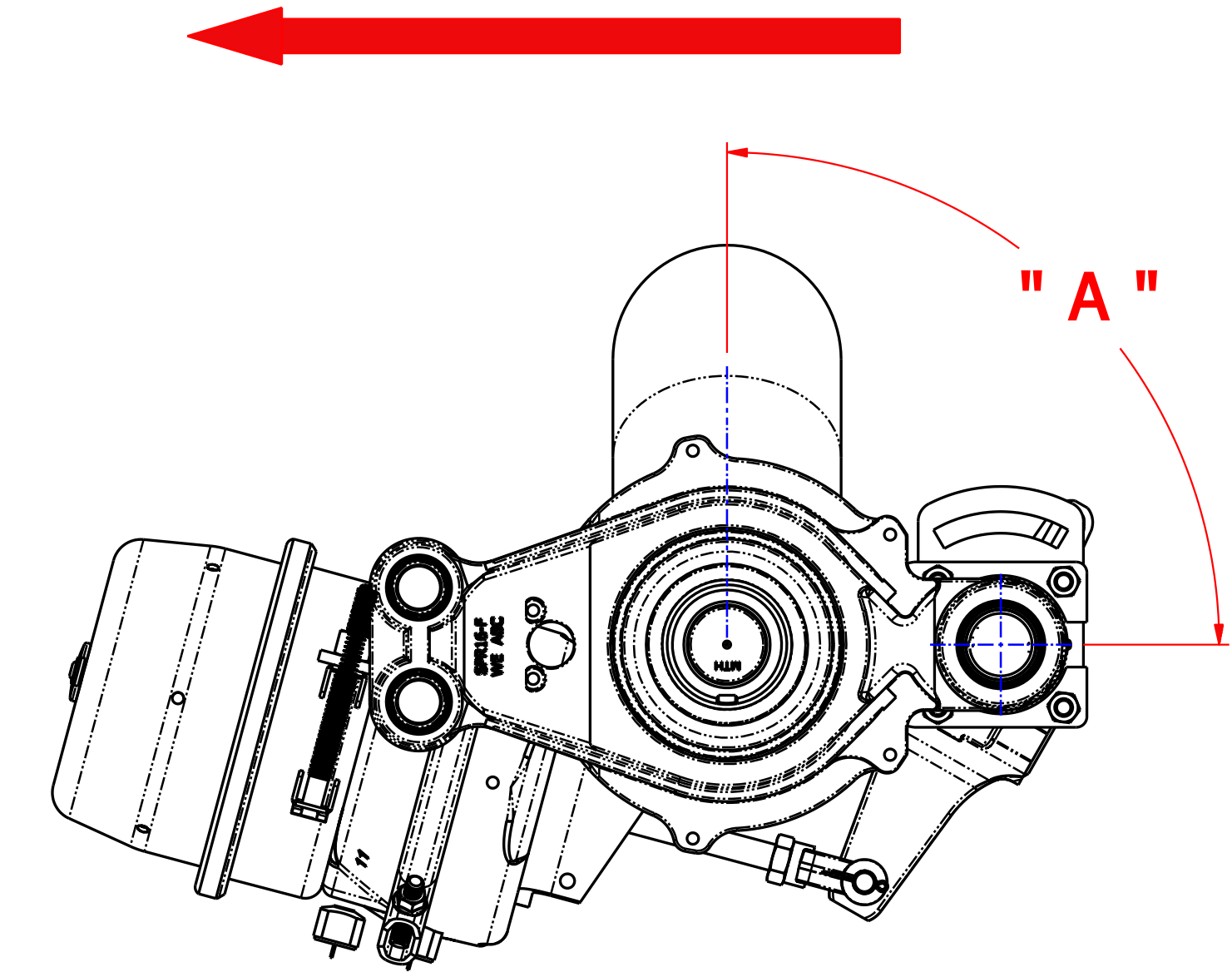

LH SIDE VIEW (HUMP UP)

CUSTOMER NAME: _____
DATE: _____
AXLE PART NUMBER: _____
REQUESTED ANGLE "A": _____
REQUESTED CAM LENGTH "B": _____
HUMP DIRECTION OPTION: _____

NOTES:

MATERIAL: _____
 OPT. MATERIAL: _____
 HEAT TREATMENT: _____

BREAK ALL SHARP EDGES

	DRAWN BDF	DATE 7-06-2021	MTH MANUFACTURING INC.	
	CHECKED MAH	DATE 7-06-2021	D22 AXLE ASSEMBLY BENT TUBE FRONT & REAR VIEWS	
	<small>UNLESS OTHERWISE SPECIFIED TOLERANCES ARE AS FOLLOWS: X.XX ± 0.76 MM [.03 IN] X.XXX ± 0.254 MM [.010 IN] ANGULAR TOLERANCE ± 1.0° CHAMFER TOLERANCE ± 5' SURFACE FINISH $\sqrt{\text{ }}$</small>		SIZE D	DWG. NO. D22 SCALE
			SHEET 1 OF 2	